

OPERATIONAL EXPERIENCE WITH SUBSEA MULTIPHASE FLOW METER

Elisio Caetano, Petrobras, Brazil
Jose Alberto Pinheiro, Petrobras, Brazil
Claudio Barreiro da Costa e Silva, Petrobras, Brazil
Cassio Kuchpil, Petrobras, Brazil
Eivind Dykesteen, Fluenta, Norway

1 INTRODUCTION

Monitoring of the multiphase flow at the wellhead eliminates the need for dedicated test lines from remote wellhead completions, and the need for a dedicated test separator at the processing facility. A multiphase flow meter at the wellhead will also allow improved well control, and hence better reservoir control. For remote or deep subsea wellhead completions the savings and operational benefits offered by this new technology are quite extensive.

PETROBRAS, for more than one decade, has been supportive to the development of the multiphase metering technology. It has come from internal R&D educational investigations to a point in which strong technological co-operations have been celebrated with the main conception holders and manufacturers of the most promising concepts of multiphase meters. Its supportive posture is aiming for the acceleration of the mature availability of such technology and its immediate introduction in the production practices - such effort has been considered as a Technology Implementation Project (TIP) when considering its ultimate nature. In addition, by considering the enhanced chances of success of such TIP when allowing the participation of other petroleum companies, as well as the benefits of a sooner spread out of the technology following a qualification success, PETROBRAS decided to offer such participation through the modality of a Joint Industry Project (JIP). Such decision received full support of the Company non-exclusive Partner, FLUENTA, which also accepted the responsibility of leading such JIP that since the first moment has counted with the strong support of eight petroleum companies - AMERADA HESS, ARCO, CHEVRON, CONOCO, ELF, EXXON, SHELL and TEXACO.

In summer of 1997, Petrobras installed a Fluenta multiphase meter in a subsea production manifold, at 450 meter water depth at the Albacora field offshore Brazil. 20 months later, at the end of January 1999, the meter was powered up, signal communication was established, and calibrations were checked and verified. First oil through the meter was in early May 1999. The paper reports the operational experiences from the first year of operation, and also gives an evaluation of the measurement performance, compared to the conventional test separator.

2 THE FLUENTA MPFM 1900VI MEASUREMENT TECHNOLOGY

The Fluenta multiphase meters are specifically designed to handle the various, and often complex, flow regimes that must be expected, without introducing mixing or separation of the flow. This has been achieved by developing a unique method for interpretation of sensor signals, the Dual Velocity method. This method is capable of handling complex flow regimes, including severe slugging, inhomogeneous phase distribution and interphasial slip.

2.1 Measurement principle

The MPFM 1900VI measurement system consists of a capacitance sensor, an inductive sensor, a gamma densitometer, a venturimeter and a system computer. The mean dielectric constant of the flow is measured using a non-intrusive, surface plate, capacitance sensor. The mean density

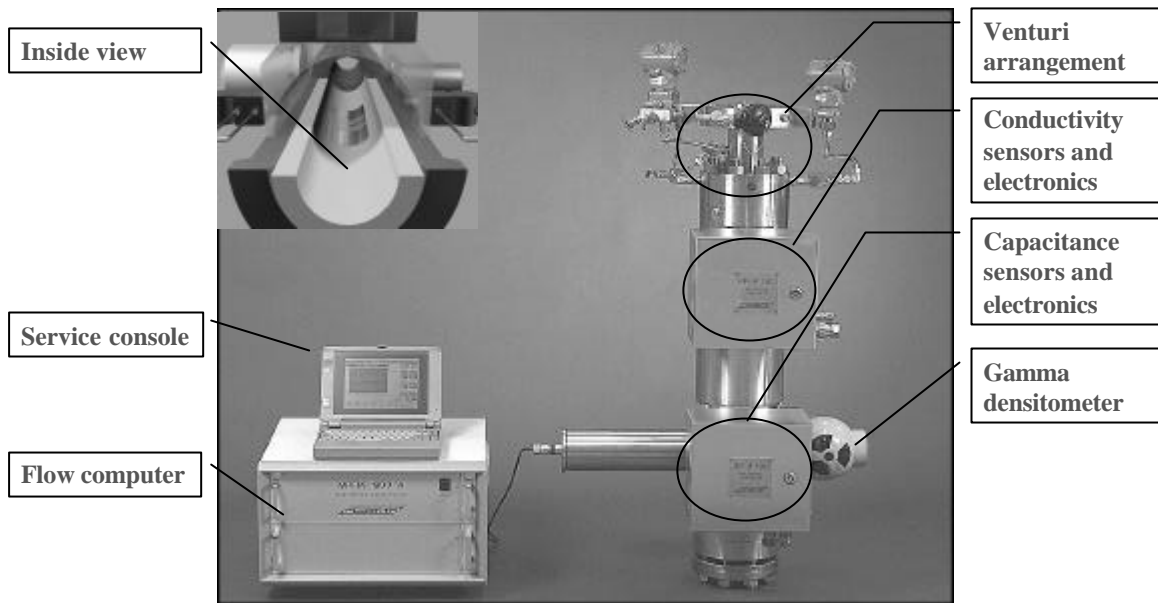

Figure 2.1 -The Fluenta MPFM 1900VI; Block diagram

of the flow is measured using a clamp-on gamma densitometer. Together these two measurements provide the instantaneous composition of the flow at the measurement location. At high water cut, when water is the continuous liquid phase, the mixture conductivity is measured using an inductive type sensor. This then replaces the capacitance measurement in the composition calculation. Velocity of the flow is determined by cross-correlation between different electrode pairs in the capacitance sensor. A venturi meter extends the range of the multiphase meter to cover single phase liquid and annular flow, and add redundancy to the velocity measurement. By combining both the compositional and the velocity information of the flow, the actual flowrates of oil, gas and water are determined by mathematical models hosted in a PC system.

2.2 The Dual Velocity Method For Handling Of Interphasial Slip

The sensor system has been configured to measure the distribution of velocities present in the flow, and interphasial slip is directly measured and compensated for using the unique “Dual Velocity method”. This is achieved by measuring the two most predominant velocities in the multiphase velocity distribution; the velocity of the pseudo-homogenous dispersed phase, and the average velocity of larger gas bubbles.

By combining these velocities with measured cross-sectional area fractions of dispersed phase and “large bubbles”, flowrates of oil, gas and water can be calculated, irrespective of flow regime (restricted to vertical upwards flow). In a somewhat simplified way, one can explain the Dual Velocity method to treat the flow as a “two-phase” mixture in terms of velocity: a pseudo-homogeneous mixture of oil, water and small gas bubbles; and a “free” phase consisting of larger gas bubbles travelling with an average velocity significantly higher than that of the “dispersed phase”.

The non-intrusive design, together with the Dual Velocity method for handling of phase slip, means the Fluenta multiphase meters do not require mixers to homogenise the flow, or separator to split the flow, before measurement. This gives the meter a wide operating range, which is not limited by the efficiency of the upstream flow conditioner or splitter. Interaction with the flow is kept to a minimum, avoiding pressure drop, erosion, or creation of emulsions that may otherwise seriously affect the downstream process.

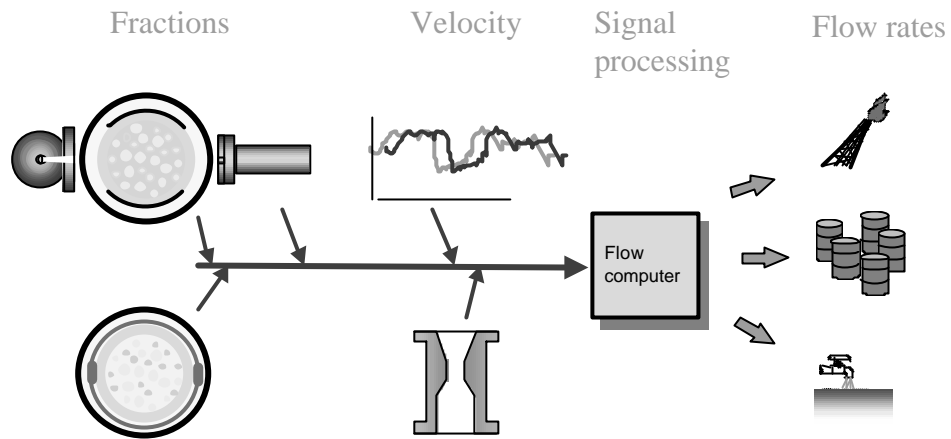

Figure 2.2 - The Fluenta measurement principle

3 THE FLUENTA SUBSEA MULTIPHASE METER SMFM 1000

The subsea version of the MPFM 1900 series multiphase meters, the SMFM 1000, incorporates the same basic primary sensor elements and measurements principles as the topside version. One exception for the meter delivered for the Albacora field application, is that it does not contain the inductive sensor module, limiting the operational range to low water cut (below ~ 60 - 80% water cut).

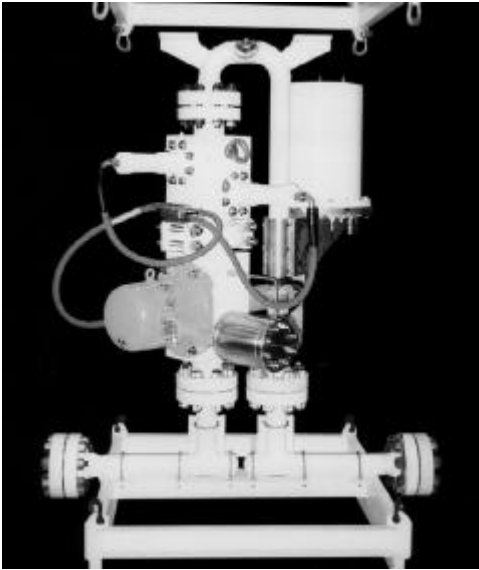

Figure 3.1 -The Fluenta SMFM 1000, mounted on test skid

In Figure 3.1, the meter is pictured mounted on a test skid. When installed subsea, this test skid was replaced by a dual bore flange arrangement. The detector electronics and flow computer is installed in an atmospheric chamber next to the flow meter itself, and connected to the meter through oil-filled cables. This complete sensor assembly is installed in a subsea retrievable module, guidelineless and cable deployed, the MMS 1200 designed by Petrobras.

4 THE ALBACORA FIELD APPLICATION

The project for developing the Albacora Field - Phase II utilizes an FPSO vessel (P-31, Vidal de Negreiros) to receive the produced fluid from four production manifolds and to provide water to an additional manifold for injection. The four subsea production manifolds, MSPDL-3, 4, 5, and 6, are designed to accept a multiphase meter in a retrievable module (see Figure 4.1). The first production manifold fitted with a multiphase meter was the MSPDL-3. In May 1997, the Fluenta Subsea Multiphase Meter SMFM 1000 was integrated into the host manifold (constructed by CBV). In June 1997, this manifold was installed on the sea floor, at 450 water depth, in the Albacora field. The location of the Albacora Field in the Campos Basin is shown in Figure 4.2.



Figure 4.1 - The meter is installed within a retrievable unit, the MMS 1200.

The main purpose of this measurement system is to allow more accurate and continuous reservoir monitoring (well testing). In addition, the subsea multiphase flow measurement system is expected to provide economic benefits, such as the elimination of subsea testing lines and simplification of subsea production systems. The use of this technology is also part of the developed concept of a "Remote Operated Platform."

The actual concept of the project utilizes guidelineless installation and recovery of such a flow meter without production interference. This is accomplished by installing the multiphase meter in a retrievable module, the MMS 1200, designed by Petrobras. The manifold piping arrangement allows well production to be routed:

- Through the SMFM 1000 to the test line and a test separator on the FPSO.
- Through the SMFM 1000 to the production line.
- Directly to the production line or test line without passing through the SMFM 1000.

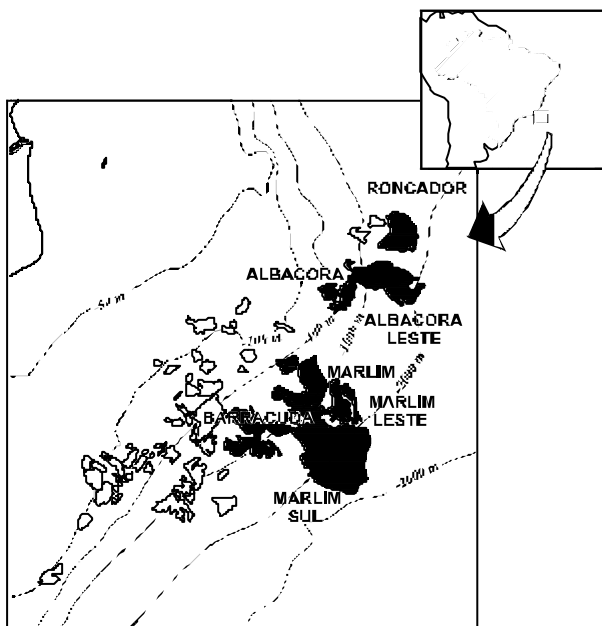

Figure 4.2 - Campos Basin offshore Brazil

Data from the Fluenta subsea multiphase meter is compared with data reported by the test separator system on the Vidal de Negreiros FPSO. This is a conventional reference system, and being composed by a three-phase separator vessel, hydro-cyclone device at the water-outgoing stream, BS&W analyser and related instrumentation.

5 EXPERIENCES DURING INSTALLATION AND COMMISSIONING

The SMFM 1000 Subsea Multiphase Meter embarked on the PETROBRAS MMS-1200 module that ultimately was installed in the production manifold MSP-DL3 (Albacora field). Basic operating conditions are translated by 20×10^{-3} Pa.s oil viscosity @ 38 °C, 300-1000 m³/d oil flow rate, 60-80 % GVF, 0-50 % WCUT and 60 bar in pressure.

At the CBV-CANECO shipyard in Rio de Janeiro, Brazil, the SMFM 1000 was functionally tested after its assembly in the MMS-1200 module and the module installation ("dry deployment") in the manifold. Such test checked the meter-module transmission system communications and power supply (using an electric cable in order to simulate the control umbilical line, right connected to the clamp ring connector/jump); inside of the meter, initially we had just air flowing and later water based hydraulic fluid. Besides that, a hydrostatic test at 50 bar was performed in the Control Pod's dual ring sealing system, in order to assure its proper operation when in the deep sea.



Figure 5.1 -The Vidal de Negreiros FPSO

After the subsea deployment (Jun. 1997) a functionality test, by means of connecting the control umbilical to the host MSP-DL-3 manifold, energising all electronics and checking out their operational trends and diagnosis, was executed in May 1998 from a service rig. No signal from the meter was received in the surface console. However, after taking the topside console to CENPES, it was found a malfunction on it. A proper repair was executed but no other opportunity was given for a second functionality testing using this rig (rig availability).

The DL-03 control umbilical was connected to the P-31 production platform by the end of 1998, and the Subsea Multiphase Flow Meter was connected to the surface panel using a dedicated twisted pair of this umbilical. The functionality test was carry out with success, the power supply to the subsea electronics and the meter transducers operated properly.

The flow lines and the manifold were filled with diesel oil, this allow the meter calibration using a fluid with know properties. After that, gas was pumped to the meter, thus a calibration with a second know fluid was carried out. No drift since deployment 18 months earlier was observed.

The first well test, comparing the test separator results and the subsea multiphase flow meter, was carried out at April, the difference between the flow rates measurements (after PVT adjustments) were lower than the expected uncertainty of the test separator flow rate measurements.

6 OBSERVED PERFORMANCE OF WELL TESTING

The subsea meter measurements are compared with the results of the topside separation/measurement system (taken as a conventional reference and being composed by a three-phase separator vessel, hydro-cyclone device at the water-outgoing stream, BS&W analyser and related instrumentation).

Figures 6.1 and 6.2 show the oil flow rate and accumulated oil volume, respectively, as measured by the Fluenta meter and the test separator as a function of time, on May 15 & 16, 1999, with a test duration time of ~40 hours. The relative deviation for the accumulated volume in the test period was -5.6 %.

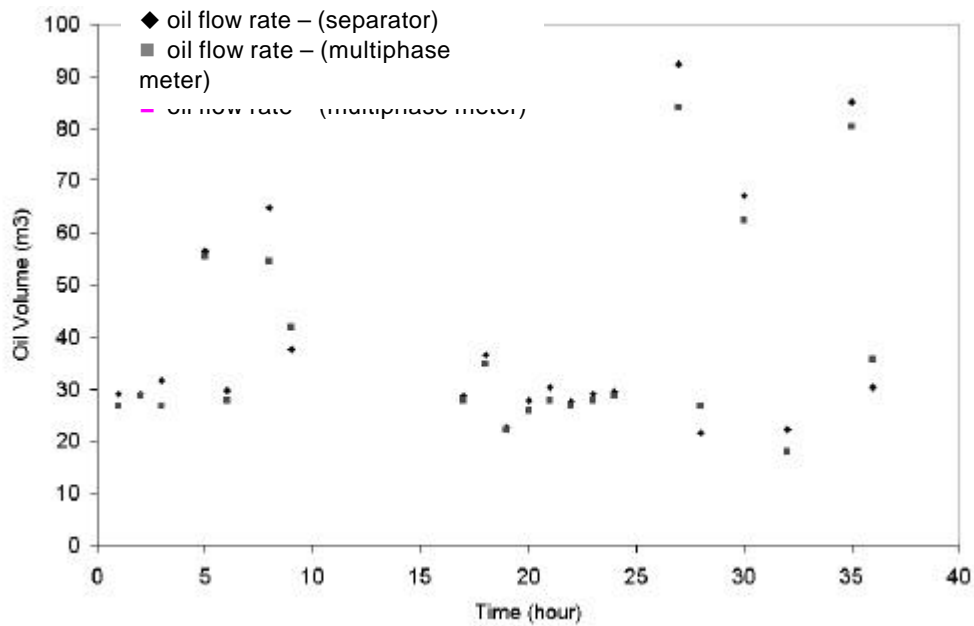

Figure 6.1 - Measured oil flow rate, versus time.

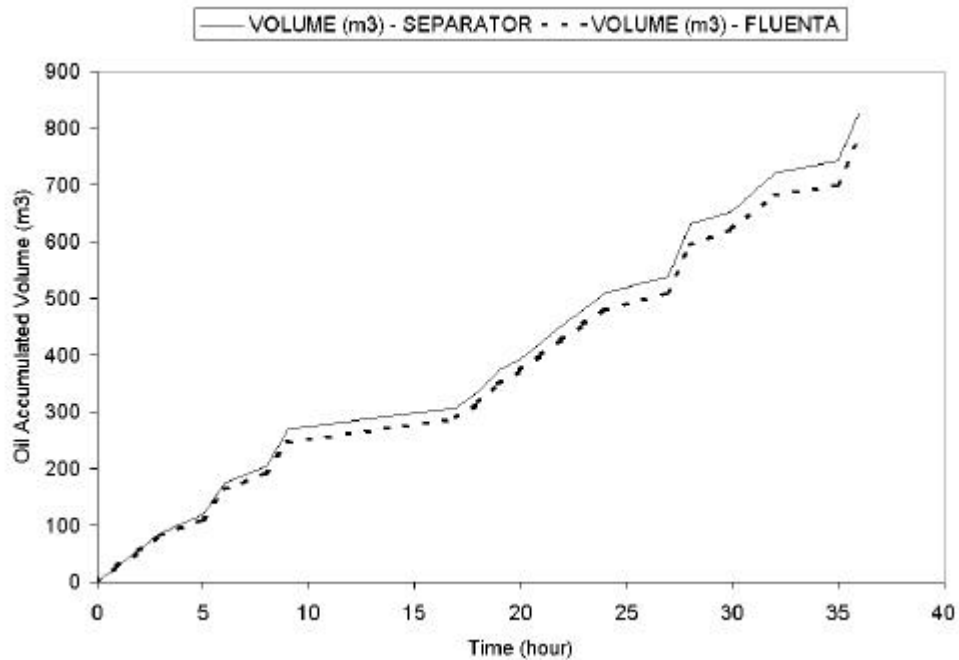

Figure 6.2 - Accumulated oil volume versus time, measured by the Fluenta meter and the test separator.

Figures 6.3 and 6.4 show the accumulated gas volume by period and the accumulated gas volume over time, respectively measured by the Fluenta meter and the test separator, with a test duration time of ~40 hours. The relative error for the accumulated volume in the test period was -1.04 %.

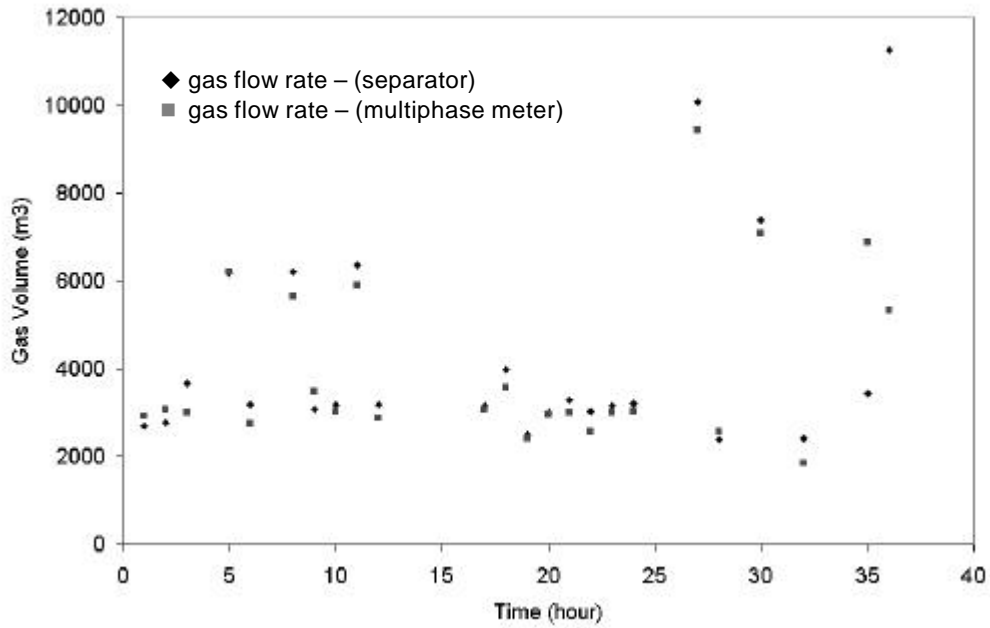

Figure 6.3 - Measured gas flow rate, versus time.

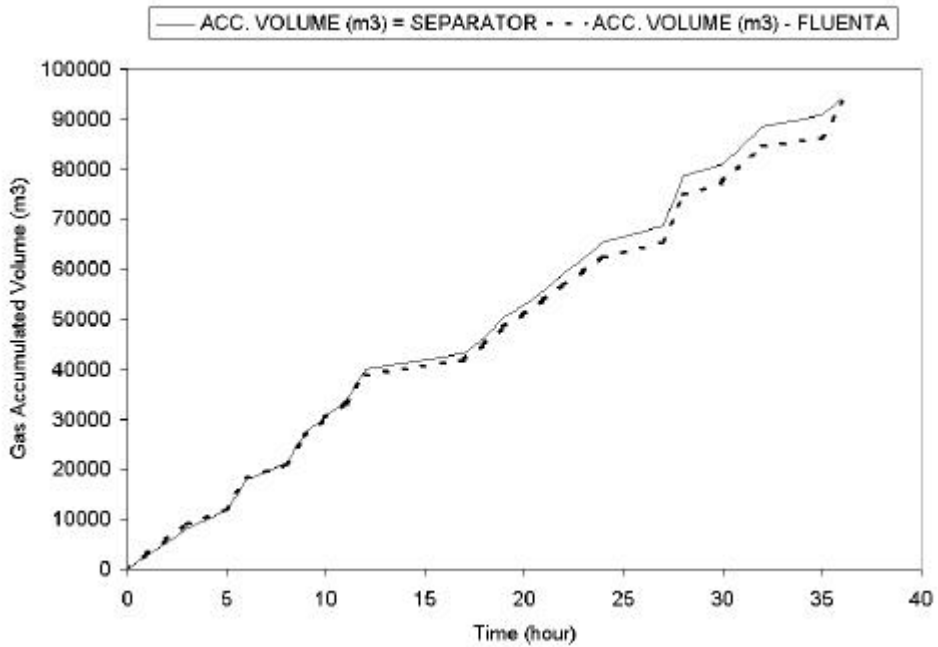

Figure 6.4 Accumulated gas volume versus time, measured by the Fluenta meter and the test separator.

7 SUMMARY OF EXPERIENCES OVER THE FIRST 12 MONTHS IN OPERATION

During the first year operation the subsea multiphase flow meter there was just one well producing to the DL-03 manifold, the well AB-53. As this well has a relatively stable production, the main benefits of the subsea multiphase flow measurement were not completely appreciated by the production operation and reservoir management, but it was possible to verify from time to time the AB-53 production. Some operations problems at P-31 lead to difficulties to carry out regularly production tests using the test separator at the AB-53 well. The main difficulties were the following: platform team involved in platform and production problems (power supply, offload, etc.), test separator problems at the gas measurement leg, test separator engaged in some problems at other wells and even a small fire at the P-31 lodge area. During that period the meter was out of operation during three weeks. After a power loss at platform the meter showed wrong results at some sensors. It is however possible to adjust the power supply level to the subsea module from the surface panel. The previous adjust was settled at the working limit of some meter instruments, after the system start up these instruments stopped to work, the simple adjust of the power supply level solved out the problem

Within the first year of operation, it was carried out just five well tests. The main findings from these tests are the following:

- The subsea multiphase flow meter metrological performance has been good
- No drift of meter readings have been observed
- There have been no operational problems with the meter

During the last two months (of the first year in operation) the other wells have been connected to the manifold. Just one production test has been carry out with these new wells, unfortunately the test separator have been engaged in well integration and in some interventions related to DHSV problems.

With other wells integrated to the manifold the operators are starting to see the benefits of the subsea multiphase flow meter; it was specifically helpful during the integration operations. We expect that with more well tests the operators will rely more on the meter.

Installing the meter on the manifold favors its performance on account of to the high pressure and low temperature ratings, which generates a larger specific gas mass in relation to the test separator. A larger specific mass contributes to smaller slipping between the liquid and gaseous phases.

Another important, noticeable aspect was the difference in the production of the well when aligned to the test separator and by the production line. This causes large systematic errors, both in oil flow rate and in gas flow rate, for the test separator. What is the implication of such difference for the reservoir engineer?

8 FUTURE PLANS

The installation of multiphase meters on the subsea manifolds constructed for the Albacora field (Campos Basin), besides those under design and/or construction for Marlim, Marimba and Barracuda fields, all in the Campos Basin. PETROBRAS has instituted a design guideline by determining that all new production manifolds should allow the installation of a multiphase meter, which shall be immediately installed after the ongoing process of technology qualification has reached a successful end. Based on the present forecast, up to the year 2000, 27 new manifolds are planned to be built and deployed. In this scenario, the economical attractiveness of such usage is high and usually the application, especially in terms of measurement uncertainty, exhibits a better performance due to the fact that such measurements are usually done under high-pressure values. The subsea deployable and retrievable multiphase metering module (MMS 1200) has been installed in the most recently built manifolds - Albacora, Marimba and Marlim fields. The MMS is conceived to host any of the already mentioned as seen by PETROBRAS as

the most promising conceptions to be used in such environment. After a meter conception has been qualified, such MMS shall be optimized and even abandoned by then adopting concepts of subsea stacking-up modules and serving only the most prone ones to failure, with extremely reduced infra-structure (e.g., ROV's). It shall also be mentioned, that the crucial meter characteristics in this scenario are believed to reside on its adequacy to the deep-water deployment and operation (i.e., RAM exhibited levels).

9 COMPACT ROV INSTALLED MULTIPHASE METER

For future applications of subsea multiphase metering, Fluenta has developed a new generation compact ROV retrievable version: The MPFM 2000 SR system design is based on the topside meter, MPFM 1900 VI and the previous Fluenta subsea flowmeter, the SMFM 1000. The basic elements are the same as for the previous subsea meters, with a number of improvements and re-packaging.

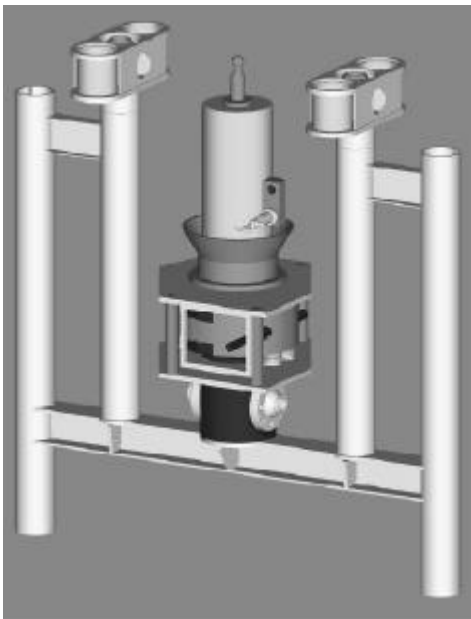

The basic elements are the same as for the previous subsea meters, with a number of improvements and re-packaging.

The mechanical interface is through a dual bore connector in the bottom. This allows simple installation by use of a well qualified and accepted locking mechanism. Electrical interface is over a ROV operable connector. This allows for connection to a subsea control module. The low power consumption of the meter allows for supply of 24VDC. The meter has redundant power supply and signal interface.

The MPFM 2000 SR is designed for 3000 meters water depth, and the design of the system is flexible with regard to selection of ROV and/or ROT interfaces as well as system components such as flowline connector(s), electrical connectors and corresponding intervention interfaces.

Figure 9.1 - The MPFM 2000 SR; here pictured with a GSR type connector

10 SUMMARY AND CONCLUSIONS

PETROBRAS and FLUENTA are conducting a non-exclusive Technological Co-operation Agreement (TCA) involving two different liquid-liquid monitors and three multiphase meters, which shall lead, among others results, to the first multiphase flow meter operation in a deep water environment. A FLUENTA SMFM 1000 assembled in a PETROBRAS subsea retrievable module, guidelineless and cable deployed, MMS 1200, was successfully installed (June 1997) in a host manifold (MSP-DL3) in the Albacora field. After several delays in the delivery of items composing the field exploitation scheme, the overall tiebacks and hook-ups are completed and the first oil has come in the 10th of May, 1999. The overall performance, including the measurement error has been considered as very good.

All the activities imbedded in the celebrated TCA with FLUENTA was offered to the industry under the modality of a Joint Industry Project (JIP) - eight petroleum companies are participating on it.

The preliminary results provided by the Fluenta meter have been excellent. The meter has reproduced equally good results in all tests performed.

PETROBRAS has decided to equip all the production manifolds under design and construction with a MMS 1200 module. Considering the present and near future production portfolios at

PETROBRAS, a mapping of the niche opportunities and the PETROBRAS views associated to this technology have been offered.

The number of meters and their diversity in conceptions installed or to be installed, not only confirms one of the PETROBRAS views for such technology but, also demonstrate how strong has been the support and decision of implementing such technology in the production practices. The impact resulting of the expected success of this venture has the potential of strongly modifying the current way of monitoring the production practices in the E&P segment of the petroleum industry.

11 REFERENCES;

- [1] NEL Test Report No 187/95: NEL Multiflow Project – Characterisation of the performance of multiphase flowmeters for oil/water/gas measurement, January 1996.
- [2] NEL Test Report No 092/97: NEL Multiflow II Project – Characterisation of the performance of multiphase flowmeters – The challenge to acceptability, January 1998
- [3] NEL Test Report No 111/97: Independent testing of Fluenta Multiphase Flowmeter for Seligi F, February 1998
- [4] Hydro Research Centre Porsgrunn Test Report No 96S_CJ5: The “Porsgrunn 2” test programme of multiphase flow meters, November 1996
- [5] ØKLAND, O., BERENTSEN, H., FLAKSTAD, G., KJØLBERG, S. A., and MOESTUE, H. “The Norwegian test programme for qualification of multiphase meters”. The North Sea Flow Measurement Workshop 1995:.
- [6] LEGGETT, B., ET AL. AI SPE 36837 Multiphase Flow Meter Successfully Measures Three-Phase Flow at Extremely High Gas Volume Fractions - Gulf of Suez, Egypt,
- [7] CAETANO, E. F., PINHEIRO, J. A. S. F., MOREIRA, C. C., and FARESTVEDT, L. OTC 8506: “MMS 1200 - Cooperation on a Subsea Multiphase Meter Application”.
- [8] SLATER, S. G., PATERSON, A. MCK., and MARSHALL, F. M. OTC 8549: “The development and use of a subsea multiphase flowmeter on the South Scott Field”.
- [9] IBRAHIM, R. “Multiphase metering in Malaysia - Current and the future“. The future of multiphase metering. 4th Annual International Conference.
- [10] MACHADO, R., CAETANO, E., and PINHEIRO, J. A. “Multiphase metering developments in Brazil”. The future of multiphase metering. 4th Annual International Conference.
- [11] MACHADO, R., CAETANO, E., KUCHPIL, C., COSTA E SILVA, C. B., and BORGES FILHO, M. J. “Multiphase metering qualification process at Petrobras – Field application stage. Field applications and new technologies for multiphase metering. 5th Annual International Conference,
- [12] STOKES, E. G., PERRY, D. T., MITCHELL, M. H., and HALVORSEN, M. “SPE 49118 Application of The First Multiphase Flow meter in The Gulf of Mexico”.

- [13] CAETANO, E. F., MACHADO, R. T. H., KUCHPIL, C., COSTA E SILVA, C. B., and BORGES FILHO, M. J. "Multiphase Metering Qualification Process at Petrobras – Field Application Stage". Petrobras Brazil Deep Offshore Technology 1999.
- [14] CAETANO, E., PINHEIRO, J. A., DA COSTA E SILVA, C. B., KUCHPIL, C., and DYKESTEEN, E. "Subsea multiphase flow metering offshore brazil". Flomeko 2000.